



R1150 R Windshield

Part Numbers: Z2330 Dark, 15.5" Tall
 Z2331 Clear, 15.5" Tall
 Z2332 Clear, 20" Tall

Read these instructions carefully and thoroughly before beginning work.

Before installing accessory, carefully consider whether one possesses the necessary technical skills and workshop tools to complete the installation properly. Otherwise, any BMW Motorcycle Retailer will be glad to install this accessory.

Tools Required:

Phillips Screw Driver	6mm Hex Key Wrench
19mm Box Wrench	5mm Hex Key Wrench
Masking Tape	3mm Hex Key Wrench
Torque Wrench	



Contents of Kit

Kit-Z2330	Qty.
1 Mount, Windshield, Upper, Left	1
2 Mount, Windshield, Upper, Right	1
3 Mount, Windshield, Lower, Left	1
4 Mount, Windshield, Lower, Right	1

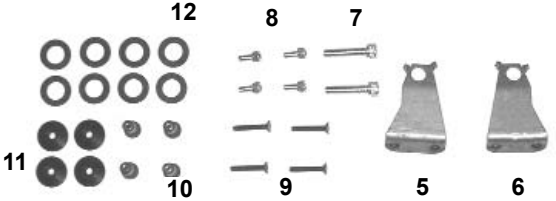

Bag #377	Qty.
5 Bracket Turn Signal Mount, Left	1
6 Bracket Turn Signal Mount, Right	1
7 Screw, M8 x 35	2
8 Screw, M6-1.0 x 12	4
9 Screw, Hex Socket, 10-32 x 1 1/4"	4
10 Wellnut, 10 SL	4
11 Finishing Washer, Screw Head	4
12 Washer, Rubber	8



Warning:	Attention:	Note:
 <p>Cautionary rules and measures which can protect the driver or other persons from injury or death.</p>	 <p>Special notes and cautionary measures which can prevent damage to the motorcycle. Failure to observe these can result in nullification of the warranty.</p>	 <p>Tips for facilitation of operation, control and adjustment, as well as maintenance work.</p>

Attention:



Make sure ignition is off.

Secure motorcycle on center stand and cover fender to prevent paint scratching.

Do not use lubricants to facilitate installation of the Wellnut assembly through the windshield (step 17). The use of lubricants may cause damage to the windshield material.

Note:



Left and right side of motorcycle is determined while sitting on the bike.



Lower Left Mount

1. Remove left turn signal lens and pull light assembly from housing. (Phillips Screw Driver)
2. Disconnect wires. Pull wires through turn signal stalk.

Note:



Note where brown wire (ground) is connected for later reassembly.



3. Pull silver trim piece from the rubber grommets along the length of the turn signal stalk to expose the 19mm nut holding turn signal stalk to the motorcycle.

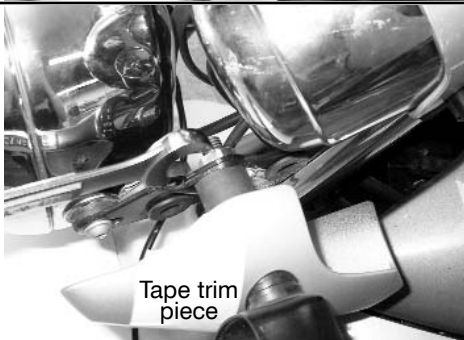

4. Cover plastic trim piece with a low tack adhesive tape to prevent scratching finish during installation.

5. Remove nut on turn signal stalk and remove turn signal stalk from motorcycle headlight bracket. (19mm Box Wrench)

Note:



Note locator tabs on turn signal stalk

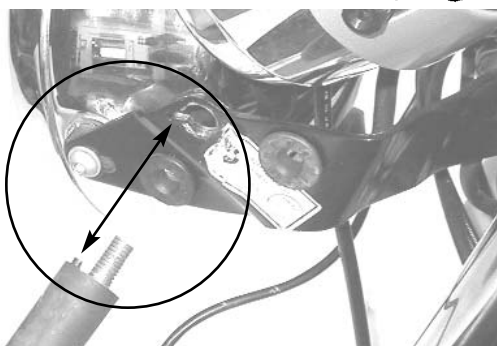

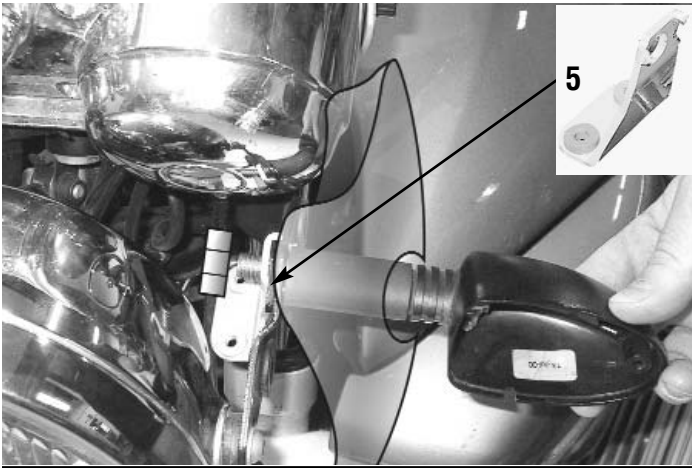

6. Locate the left “L” turn signal bracket from Bag 377. Reassemble turn signal through plastic trim piece, headlight bracket and left turn signal bracket (item 5) on turn signal stalk as shown. (Box Wrench)

Make sure locator “ears” on supplied turn signal bracket and turn signal stalk are installed correctly into the motorcycle headlight bracket. The front “ear” of the turn signal bracket will locate into the slot of the turn signal holder.

Tighten the 19mm nut to 2 Nm (20 in-lb). (Torque Wrench)



7. While being careful not to scratch plastic trim piece, assemble lower left “L” mount to left turn signal bracket using two supplied M6 x 12 socket head cap screws. (5mm Hex Key Wrench) Ensure that the end of the mount is facing forward in front of the turn signal as shown.

8. Torque the M6 screw to 8 Nm (6 ft-lb). (Torque Wrench)

9. Reassemble turn signal assembly and ensure that the silver trim piece is firmly installed in rubber grommets. Remove protective tape from trim piece.

10. Repeat steps 1 through 9 to assemble the lower right mount.



Note: 

Upper Left Mount

11. Remove M8 socket head cap screw from the underside of the top triple clamp. (6mm Hex Key Wrench)

12. Install upper left “L” mount using supplied M8 x 35 socket head cap screw. (6mm Hex Key Wrench) Ensure that the mount passes between the fork leg and gauge assembly and faces up and forward as shown. Do not tighten Screw.

Do not fully tighten M8 x 35 screw until wind shield has been installed.

13. Repeat steps 11 and 12 to assemble the upper right mount.



Rubber washer should not overhang edge of mount.

Windshield Mounting Hardware

14. Remove paper backing to expose adhesive of four supplied rubber washers and apply adhesive side to surface of mounts as shown. Rubber washer should not overhang edge of mount.

Assembly of items 11 and 12.

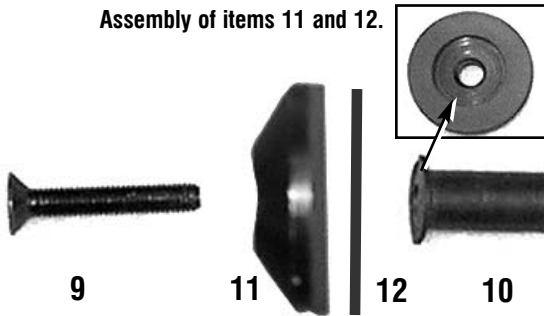

Rubber washer(12) should not overhang edge of finishing washer (11).

Note: 

15. Remove paper backing to expose adhesive of remaining four rubber washers and apply adhesive side to the flat side of the four finishing washers. Make sure rubber washers do not overhang edge of finishing washers.

16. Pass 10-32 Hex Socket Screws through the finishing washers and loosely assemble with supplied rubber wellnuts.

The flange of wellnut (10), should seat into recess of rubber washer (12).

Install Windshield

17. Hold windscreen up to mounts. Starting at the lower mounts, insert a screw assembly through windshield plastic. Ensure that the wellnut end passes through the plastic into the lower mount and that the rubber washer in the screw assembly firmly seats against the windshield surface.

18. Assemble remaining mounting hardware in the upper mounts.

19. Adjust the windshield so that the air gap around the windshield and headlight is even and the turn signals are not touching the windshield.



Install screw assemblies at the lower mount point first.

Final Adjustments

20. Once the windshield is located correctly, firmly tighten the 10-32 Hex Socket Screws so that the wellnuts are not able to be pulled from the mounts. **Do not overtighten.**

Make certain the M8 x 35 screws in Upper Mounts are seated correctly before you fully tighten. (Screw may bind during installation.) Final torque of M8 x 35 screw is 14 Nm (10 ft-lb).

21. Tighten the M8 x 35 socket head screws.

Check all remaining hardware for tightness.

22. Check that the turnsignals have been correctly installed and are operating correctly before riding motorcycle. Remove the cover protecting the fender.

Note: 

WARNING

Fahren Sie Ihr Motorrad niemals mit losen Zubehörteilen. Überprüfen Sie die Halterungen regelmäßig auf festen Sitz.

Die heutigen Motorräder sind mit einer ausreichenden Rahmensteifigkeit gebaut, um den moderaten Belastungen standzuhalten, die durch die absehbare Hinzufügung eines oder mehrerer Zubehörteile auf sie ausgeübt werden. Wenn ein oder mehrere Zubehörteile die Stabilität Ihres Motorrads beeinträchtigen, entfernen Sie sofort das / die Zubehörteil (e). Nehmen Sie kein Motorrad in Betrieb, das unsichere Fahreigenschaften aufweist.

Lassen Sie das Problem von erfahrenem Servicepersonal beheben, bevor Sie mit installiertem Zubehör fahren. Bei weiteren Fragen zu Handhabungsproblemen im Zusammenhang mit einem oder mehreren Zubehörteilen wenden Sie sich bitte an Ihren Händler, Motorradhersteller oder Zubehörhersteller.

Sonnenlicht, das von der inneren Krümmung der Windschutzscheibe reflektiert wird, kann zu bestimmten Tageszeiten zu einem extremen Wärmestau auf den Instrumenten des Motorrads führen und diese möglicherweise sogar zum Schmelzen bringen. Gehen Sie beim Parken vorsichtig vor, um dies zu vermeiden. Stellen Sie Ihr Motorrad in Richtung Sonne ab oder platzieren Sie einen undurchsichtigen Gegenstand über diesem Bereich.